

Technical specifications:

Type		Parameters
Working voltage		1.9 – 3.6V
Working temperature		-40 - 85°C
Maximum transmit power		+8dbm
Antenna		PCB onboard antenna
Receiver sensitivity		-92dbm
Average current	Wake-up mode	90uA
	Suspen mode	14uA
	Deep Sleep mode	1uA

Factory default configuration:

Service UUID: FFE0

Feature UUID: FFE1

Serial baud rate: 115200bps

AT Instruction Set

Users can communicate through the serial port and Bluetooth chip, serial port using Tx, Rx two signal lines.

Baud rate support 2400,4800,9600,14400,19200,38400,57600,115200。 The default baud rate of the serial interface is 115200bps。

Detailed description

Note: The AT command must be carriage return line, AT command can only be connected to the module to take effect. Once the Bluetooth module and device connect together, the Bluetooth module enter the data through mode.

(AT Instructions are case-sensitive and are terminated with carriage returns and line feed characters: \r\n)

1、获取版本号：Get version number:

Instruction	Response	parameter
AT+VER	+<Param>	Param: 版本 默认: +JDY-10-V1.8

2、获取蓝牙 MAC 地址 Get the Bluetooth MAC address

指令	Response	parameter
AT+MAC	+MAC: <Param>	Param: MAC 地址

3、设置蓝牙名 Set the Bluetooth name

Instruction	Response	参数
AT+NAME<Param>	OK	Param: 蓝牙名 默认名称: JDY-10 最长 18 字节

4、设置/查询-发射功率 Set / query - transmit power

Instruction	Response	parameter
AT+POWE<Param>	OK	Param: (0-5) 0: 8db 1: 5db 2: 0db 3: -5db 4: -10db 5: -13db
AT+POWE	+POWE: <Param>	

5、设置/查询-串口波特率 Set / Query - Serial baud rate

Instruction	Response	parameter
AT+BAUD<Param>	OK	Param: (0-7) 0: 115200 bps 1: 57600 bps 2: 38400 bps 3: 19200 bps 4: 14400 bps 5: 9600 bps 6: 4800 bps 7: 2400 bps
AT+BAUD	+BAUD: <Param>	

6、设置/查询-广播间隔 Set / query - broadcast interval

Instruction	Response	parameter
AT+ADVINT<Param>	OK	Param: (0-6)
AT+ADVINT	+ADVINT: <Param>	0: 100ms 1: 100ms 2: 250ms 3: 500ms 4: 1600ms 5: 3200ms 6: 4800ms

Size package

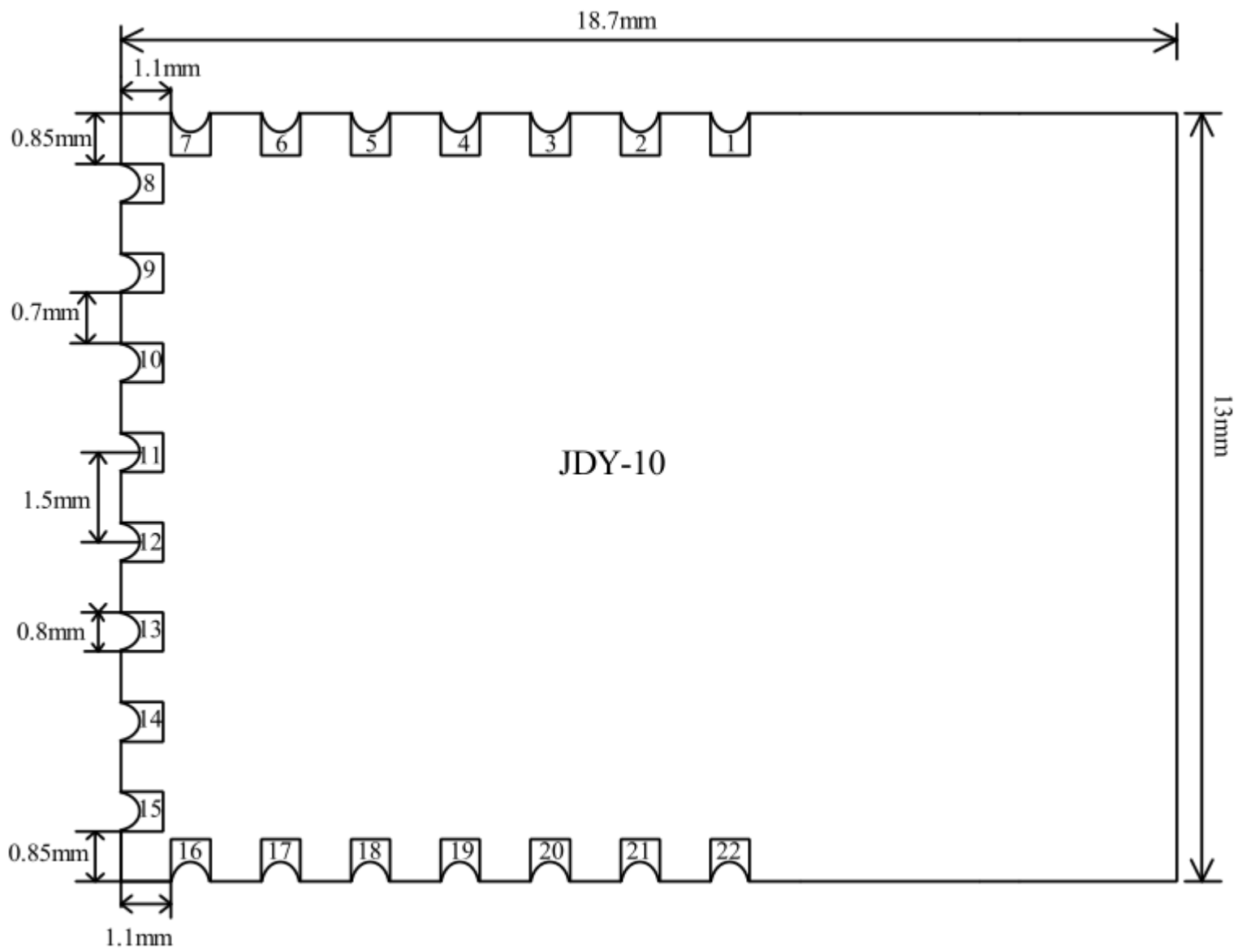

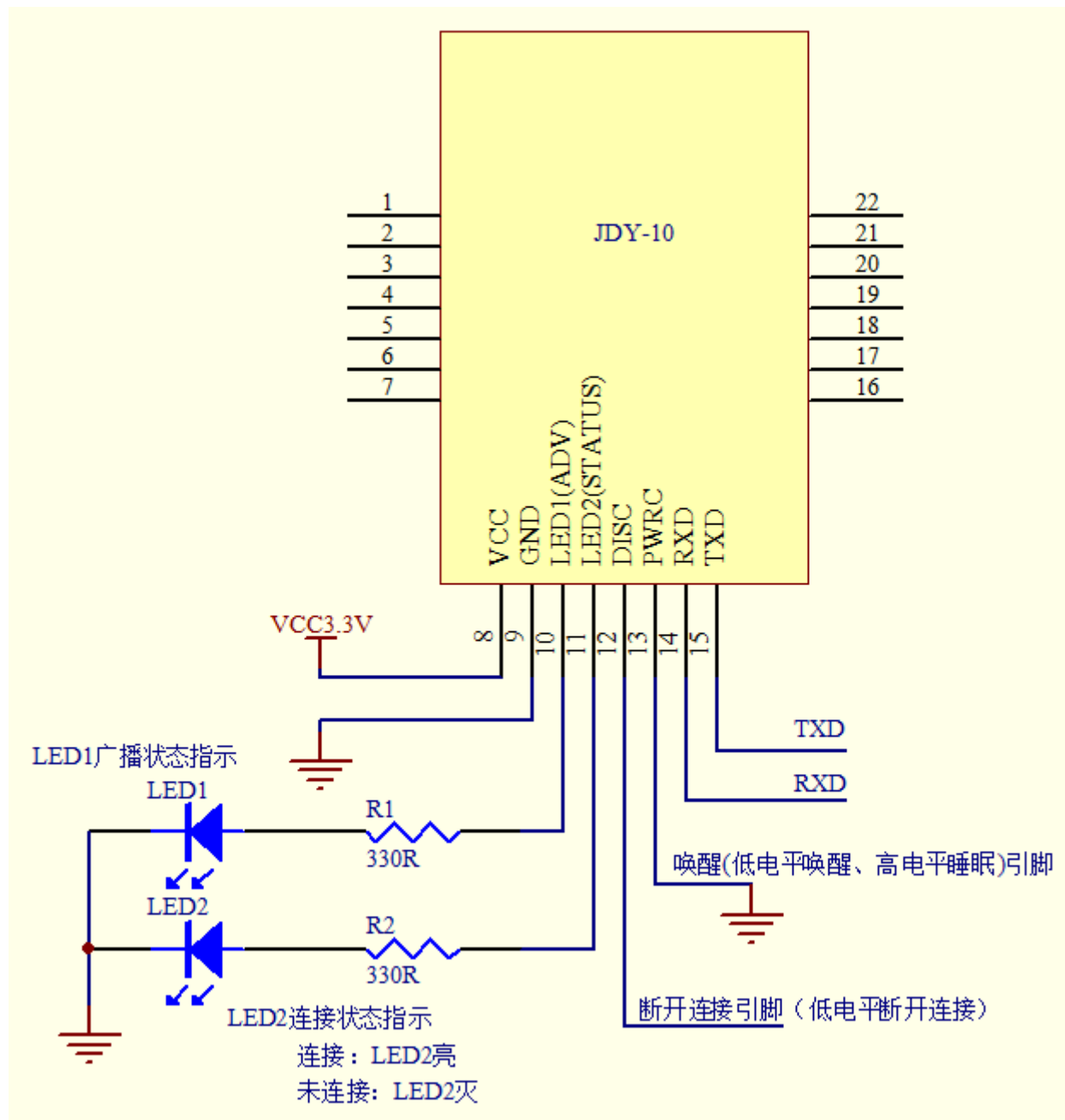

Classic Application Schematic

- 10. led1 broadcast
- 11. led2 connection status indication connection: led not connected: led
- 13. disconnect pin (low level open connection)
- 14. TXD RXD 1 muted (low level wake, high sleep)